

# Final Report

Team 2 – Cummins Electric Vehicle Optimization

Members: Samantha Beeler (smb11g), Jakob Consoliver-Zack (jic13),  
Tyler Mitchell (trm13), Jeremy Randolph (jsr13e)



**Sponsor: Dr. Michael Hays**

**Advisor: Dr. Juan Ordonez**

## Acknowledgements

Team 2 would like to thank Dr. Michael Hays and Cummins for providing the budget and design assistance to make this project a reality. Dr. Hays has helped the team tremendously with receiving the golf cart and generator that was provided by Cummins, as well as facilitating the purchase request for the power supplies that have been utilized in the design.

Team 2 would also like to thank Dr. Gupta and Dr. Camilo Ordonez for the endless hours of advice and design considerations with the circuitry components of this project. Dr. Gupta has also helped with presentation preparation and has provided constructive feedback to better the team's presentation skills.

## Abstract

Cummins would like to develop a battery-engine package for semi-trucks that can activate the engine so it can charge the vehicle's battery when it is low. Cummins provided the design team with an electric golf cart and generator to model the semi-truck. Going from initial design concepts to a working prototype required a coordinated effort from the design team along with the assistance of both the sponsor as well as supervising professors. The final design developed utilizes a mechatronic system that uses a generator to charge the golf cart's batteries as well as powers the cart's motor. When the batteries are charged the system will turn off the generator and switch the motor power source back to the batteries. Additionally heating pads are installed around the batteries and will automatically activate if the measured battery temperature drops below the ideal value. The reliability of the design was ensured by using high factors of safeties and conducting both FMEA and FEA analyses. Regardless of having a functioning prototype various elements could still be improved upon. One such element is how the batteries state of charge is measured. Due to time constraints this will have to be investigated by future senior design teams.

**Table of Contents**

<b>Acknowledgements .....</b>	<b>i</b>
<b>Abstract.....</b>	<b>ii</b>
<b>1 Introduction.....</b>	<b>1</b>
<b>1.1 Project Definition.....</b>	<b>1</b>
<b>1.2 Need Statement .....</b>	<b>1</b>
<b>1.3 Design Requirements &amp; Objectives .....</b>	<b>2</b>
<b>2 Background Research.....</b>	<b>2</b>
<b>2.1 Lead Acid Battery.....</b>	<b>2</b>
<b>2.2 Output vs. Temperature.....</b>	<b>3</b>
<b>2.3 Charging and Discharging .....</b>	<b>3</b>
<b>2.4 Generator Operation in Cold Weather Conditions .....</b>	<b>4</b>
<b>3 Concept Generation .....</b>	<b>6</b>
<b>3.1 HOQ.....</b>	<b>6</b>
<b>3.2 Concept Generation and Evaluation.....</b>	<b>7</b>
3.2.1 Selection Criteria.....	7
3.2.2 Generator Location.....	8
3.2.3 Battery Warming Method.....	10
3.2.4 Ensuring Generator Operation .....	11
3.2.5 Charging System .....	12
<b>3.3 Selected Design for Golf Cart .....</b>	<b>14</b>
<b>4 Final Design .....</b>	<b>15</b>
<b>4.1 Major Systems .....</b>	<b>16</b>
4.1.1 Power System.....	16
4.1.2 Control Circuit .....	17
4.1.3 Input From Sensors .....	18
4.1.4 Auxiliary Loads.....	18
<b>4.2 Mechatronic System .....</b>	<b>19</b>
<b>4.3 Design for Manufacturing.....</b>	<b>20</b>
4.3.1 Mount Fabrication .....	20
4.3.1.1 Generator Mount .....	20
4.3.1.2 Propane Tank Mount .....	21
4.3.1.3 Power Supply Mount.....	22
4.3.2 Circuit Mounting .....	23
4.3.2.1 Circuit.....	23
4.3.2.2 Relay Location .....	24
4.3.2.3 Sensor Location.....	26
4.3.2.4 Microcontroller and LCD Display.....	26
<b>4.4 Design for Reliability .....</b>	<b>26</b>
4.4.1 Factors of Safety .....	27
4.4.1.1 Relays.....	27
4.4.1.2 Transistors .....	27
4.4.1.3 Diodes .....	28
4.4.2 FMEA.....	28
4.4.3 FEA .....	30

4.4.4	Reliability Summary .....	30
<b>4.5</b>	<b>Operation Instruction.....</b>	<b>31</b>
4.5.1	Starting the System .....	31
4.5.2	During Operation .....	32
4.5.3	Stopping the System.....	32
<b>5</b>	<b>Systems Testing .....</b>	<b>33</b>
<b>5.1</b>	<b>Transistor-Relay Test.....</b>	<b>33</b>
<b>5.2</b>	<b>Power Supply Test.....</b>	<b>33</b>
<b>5.3</b>	<b>Power Switching Test .....</b>	<b>34</b>
<b>6</b>	<b>Considerations for Environment, Safety, and Ethics .....</b>	<b>34</b>
<b>7</b>	<b>Project Management.....</b>	<b>35</b>
<b>7.1</b>	<b>Schedule.....</b>	<b>35</b>
<b>7.2</b>	<b>Resources.....</b>	<b>36</b>
<b>7.3</b>	<b>Procurement.....</b>	<b>36</b>
7.3.1	Budget Breakdown.....	36
7.3.2	Market Hybrid Golf Carts .....	38
<b>7.4</b>	<b>Communication.....</b>	<b>38</b>
<b>8</b>	<b>Conclusion .....</b>	<b>39</b>
	<b>References.....</b>	<b>40</b>
	<b>Appendix A .....</b>	<b>A-1</b>
	<b>Appendix B .....</b>	<b>B-1</b>
	<b>Appendix C.....</b>	<b>C-1</b>

## Table of Figures

Figure 1.	Charge profile for lead acid batteries. ....	4
Figure 2.	House of quality used to determine most important engineering characteristics. ....	6
Figure 3.	Photograph of the back of the golf cart. ....	9
Figure 4.	Carriage design concept. ....	9
Figure 5.	Heating pad design concept.....	10
Figure 6.	Simplified system diagram .....	14
Figure 7.	Power system circuit.....	16
Figure 8.	Circuit diagram of control circuit.....	17
Figure 9.	Heating pads and charger circuit. ....	19
Figure 10.	State diagram of mechatronic system.....	19
Figure 12.	Photograph of the propane tank mount. ....	22
Figure 11.	Photograph of generator mount. ....	21
Figure 13.	Assembly showing how the power supplies are fastened to mount plate. ....	22
Figure 14.	Power supplies fully mounted in cart. ....	23
Figure 15.	Access panel with the motor relays and terminal blocks mounted to it. ....	24

Figure 17. Heating pad (HP) and Charger (CH) relay location. .... 25  
 Figure 16. Photo of the access panel. .... 24  
 Figure 18. Photograph of the generator with the relay location circled. .... 25  
 Figure 19. Photograph of where current sensor, circled, is mounted. .... 26  
 Figure 20. FEA conducted on generator mount. .... 30  
 Figure 21. Pie chart of budget breakdown. .... 36  
 Figure 22. Bad Boy AMBUSH iS hybrid cart ..... 38  
 Figure 23. Fall Semester Gantt Chart ..... B-1  
 Figure 24. Spring Semester Gantt Chart. .... B-2

**Table of Tables**

Table 1 Generator Location Pugh Matrix ..... 10  
 Table 2 Battery Heating Method Pugh Matrix ..... 11  
 Table 3 Ensure Generator Operation Pugh Matrix ..... 12  
 Table 4 Charging System Pugh Matrix ..... 13  
 Table 5. FMEA of design components. .... 29  
 Table 6. ME Purchases ..... C-1  
 Table 7. EE Purchases ..... C-2

# 1 Introduction

## 1.1 Project Definition

Many semi-truck drivers sleep in their truck cabins and power the cabins heating and cooling systems off of the truck battery. This forces the drivers to waste fuel by leaving their engine on or to go without the systems. In harsh weather conditions where heating and AC are necessities this presents a safety risk. To prevent this issue, Cummins would like to develop a “hotel system of charging” method. This concept will include a battery/engine package that integrates a mechatronic system that will activate the truck engine to charge the battery when it is low. Cummins has provided the design team with an electric golf cart to develop a proof-of-concept design for this system of charging.

## 1.2 Need Statement

This project is sponsored by Cummins under the supervision of Dr. Michael Hays and under the guidance of the team’s faculty advisor, Dr. Juan Ordonez. At present the electric vehicle cannot operate at cold temperatures, and its range is more limited that is desired. The purpose of this project is to simulate the issue of semi-truck cabins draining the battery. The design team needs to modify the current golf cart system by utilizing a secondary power source. This power source will represent a Cummins made ISX-15 diesel engine. Dr. Hays informed the team that Cummins would be providing them with a generator to implement in their design. Since this is a small-scale simulation, Dr. Hays has provided the team with two issues with the current golf cart. The range needs improvement and the vehicle does not operate in cold weather. As such Team 2 has formulated a need statement for the project:

**“Semi-truck cabin electronics drain the batteries, and force the driver to keep the engine running. This is translated down to an electric golf cart, verifying the current range is unsatisfactory and needs to operate in cold weather conditions.”**

## 1.3 Design Requirements & Objectives

From the meetings with the sponsor the requirements of the project were formulated. Dr. Hays desired that a generator be installed into the golf cart to serve as the charging power source for the battery. He also desired that the generator activate when the battery level drops below a certain threshold, and that the generator deactivate when the batteries are charged. In addition to the automatization of the generator charging system he requested that a battery monitoring system also be implemented. Additionally all of these modifications would be made in efforts to apply this to semi-trucks. The project's overall goal statement was developed by generalizing these requirements and is given below:

**“To increase the current range and operable conditions of the electric vehicle by utilizing a secondary power source in efforts to apply this to semi-trucks.”**

In order to ultimately accomplish this goal it was necessary to determine the primary objectives for the project which are listed below:

### **Objectives:**

- ◆ **Increase the lower temperature limit to -29°C.**
- ◆ **Document current system performance.**
- ◆ **Incorporate a generator.**
- ◆ **Integrate a battery monitoring system.**
- ◆ **Ensure that the golf cart can charge and be in operation simultaneously.**

## 2 Background Research

### 2.1 Lead Acid Battery

Lead acid batteries use a chemical reaction to produce a voltage between the terminals. Two types of lead plates, spongy lead and lead dioxide, are used in these batteries and are submerged in sulfuric acid. When the lead plates come in contact with the acid, a chemical



reaction occurs in which lead sulfate is produced, along with water and useable energy in the form of a voltage difference. Since the energy is produced by a chemical reaction, temperature can effect this reaction in multiple ways.

## 2.2 Output vs. Temperature

Lead acid batteries utilize the chemical energy produced from the reactions taking place, and heavily rely on temperature as a function of voltage output. As the temperature of the battery drops, the voltage output can decrease. This is due to the internal resistance increasing as the temperature decreases as well as a decrease in reaction time, therefore lowering the battery capacity. A fully charged battery will output 100% capacity at a temperature of 27°C, however at -18°C, the battery will only delivery about 50%. [1] Most batteries will stop operating at about -20°C, however lead acid batteries will have a decreased output at this temperature. This relationship is important to know for electric vehicle drivers. The range for these vehicles is calculated at ambient room temperature, and lower temperatures will decrease the range.

## 2.3 Charging and Discharging

Although batteries can operate on a large range of temperatures, it is important to maintain an optimal temperature while charging. Lead acid batteries can charge and discharge at a temperature range from -20 °C to 50 °C, however at colder temperatures the charging process is more delicate than discharging and can possibly cause damage to the battery [1]. The optimal temperature for cold weather charging is between 10 °C and 30 °C, and will allow a fast charge time. Although the battery will discharge at fairly low temperatures, maximum discharge rates will be achieved at an optimal temperature of about 20°C. This allows the chemical reaction to take place and discharge the produced energy at a nominally rate by allowing faster reaction time.

During charging, lead acid operate on a constant current constant voltage (CC/CV) charge profile. This method regulates the current until the terminal voltage reaches the upper charge voltage. The current then drops down due to saturation [1]. The charge time for an 8 volt

lead acid battery is roughly 5-8 hours for a 70% charge, and can take another 7-10 hours to fully charge. The plot below shows a charge profile for lead acid batteries.

It is important to charge lead acid batteries after each use to ensure the sulfuric acid does not crystallize. If the battery is stored on a low charge, the battery can be permanently damaged due to crystallization. To ensure a longer lifetime for the battery check that the water level is maintained at the proper level and avoid charging if the battery is above  $^{\circ}49C$  [1].

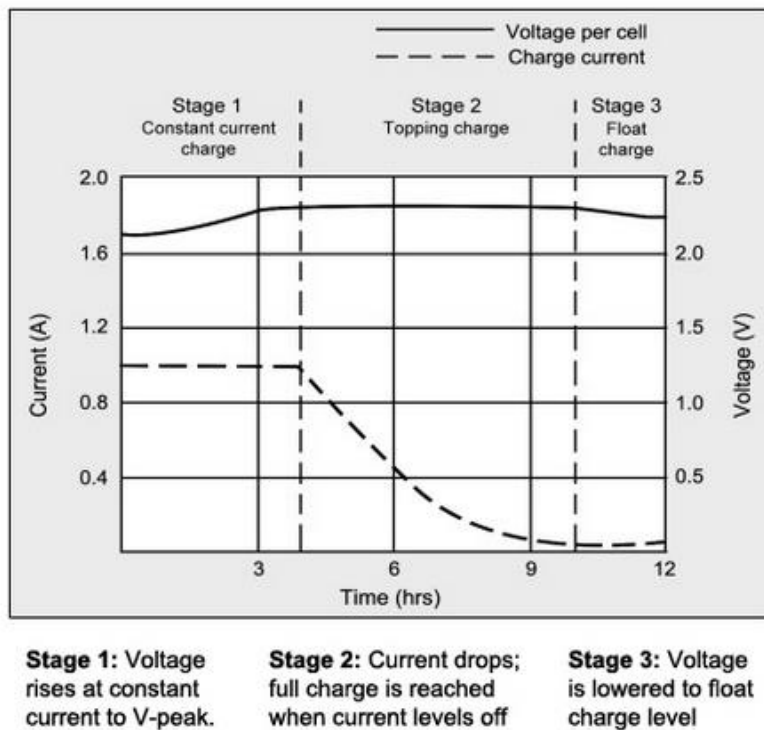

Figure 1. Charge profile for lead acid batteries.

## 2.4 Generator Operation in Cold Weather Conditions

Portable generators are readily available and provide safe power during an emergency situation or for recreational purposes. Generators generally run off of gas or propane, in which both have their advantages and disadvantages. Gas is easily obtainable and the most common source of fuel for generators, however gasoline can be expensive and toxic. It can easily be spilled and pollute the environment and the toxic fumes are extremely flammable. Propane on the other hand comes in a cylinder, making it nearly impossible to spill. However the fumes are

still toxic and flammable. Propane is not as efficient as gasoline and is almost useless at  $-29^{\circ}\text{C}$  [2]. Generators can utilize synthetic oil to ensure the generator can operate in cold weather conditions; however the user will run into the problem of the propane being too cold to operate. Since propane is highly flammable, it is not recommended to add a heat source to the tank to warm it up, but it may be necessary to warm the tank up to room temperature before the user can resume operation. Another problem with propane power, is a reduced output if the tank is half empty and cold. This could cause the generator to shut off completely until the tank is refilled or warmed to room temperature.

### 3 Concept Generation

#### 3.1 HOQ

When deciding on what aspects of a design are the most integral to the success or quality of a project, it is important to have some quantifiable measure that can be used to assess the relation between a customer’s requirements and the necessary design functionality. In terms of design methods, a common method to determine this intricate relation is called a house of quality or HOQ for short, pictured in Figure 2. This tool allows an easy visual aid to quickly see the correlation between customer requirements alongside the firm engineering characteristics. In order to determine the most important customer requirements, the team spoke with the sponsor

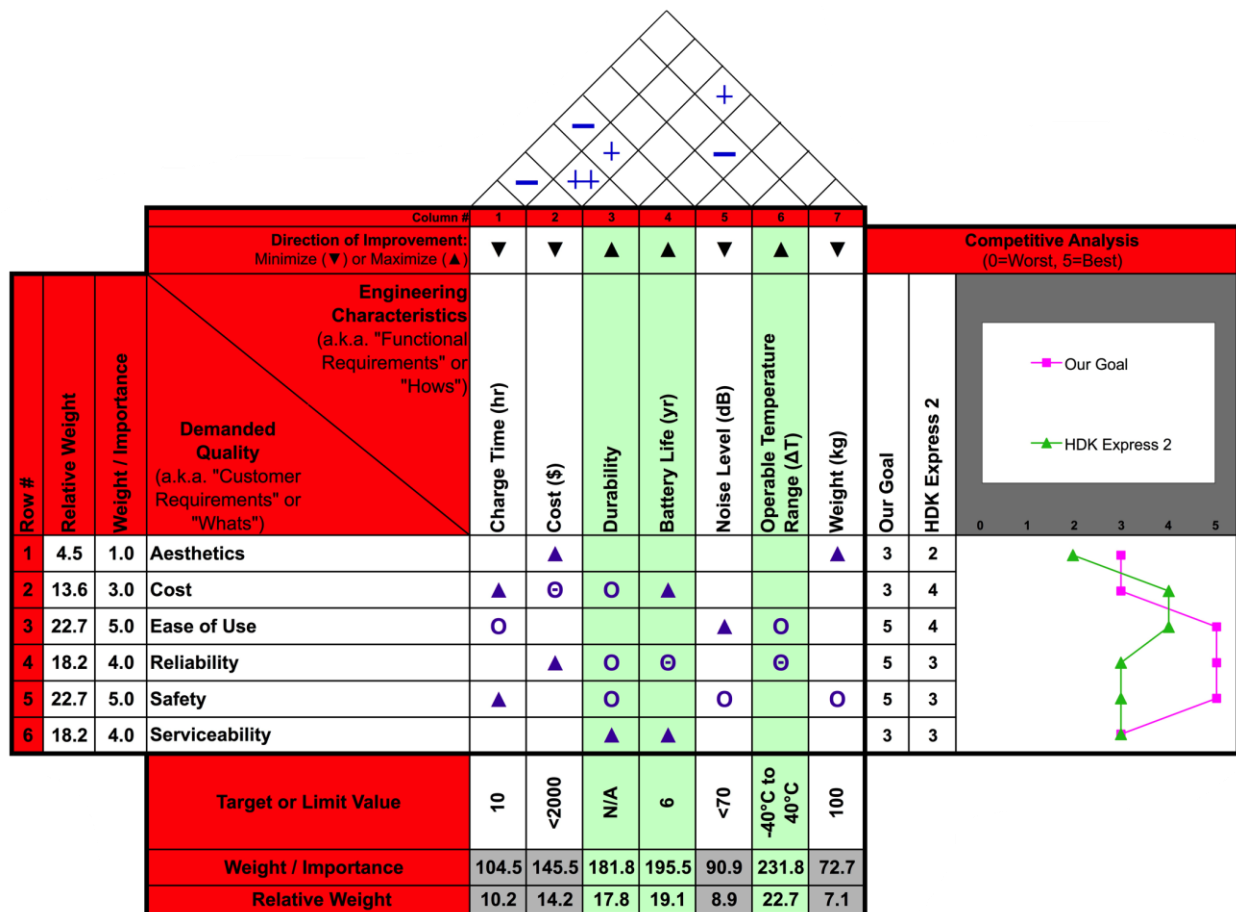

Figure 2. House of quality used to determine most important engineering characteristics.

and asked him to rank his customer requirements on a scale of one to five; with five being the highest value, and thus signifying the criteria that is of the most importance to the customer. The customer requirements included the following: aesthetics, cost, ease of use, reliability, safety, and serviceability. The customer requirements with the greatest importance were ease of use and safety, which were both given a rank of five. Next up with ranks of four were serviceability and reliability. And with ranks of three and one respectively were cost and aesthetics. The engineering characteristics that were selected as firm aspects of the design were charge time, cost of improvements, durability, battery life, noise level, operating temperature, and weight. The benchmark that can be seen on the right is the average golf cart on the market, which is the HDK Express 2 golf cart. Team two compared the design goal with the HDK Express 2 and found that while the benchmark did cost less due to a lack of a generator, the intended design of team two was more favorable in reliability, ease of use, and safety. The chart shows that there is a strong correlation between durability and battery life. As such it would make sense that more expensive materials will prove more durable and battery packs that have longer battery life will generally have a higher price as well. Once weights were given to the relationships between the characteristics, the relative weights were calculated along with the customer requirements. With this knowledge in tow, the highest ranked characteristics are operating temperature, battery life, and durability. As such, these shall be the most important parameters when attempting to improve the current system.

## 3.2 Concept Generation and Evaluation

### 3.2.1 Selection Criteria

The design was developed using the morphological method, which breaks up the overall design problem into simpler sub-problems and solution concepts are generated for them. [3] The sub-problems or parameters for this design include: where to locate the generator, how to warm the batteries to an operable temperature, how to ensure the generator will operate at  $-29^{\circ}\text{C}$ , and what charging system will be used. Three possible solutions were developed for each of the problems and the best solution was chosen using a Pugh chart. The first option for each problem was set as the datum that the other solutions were weighed against. The solutions were rated

using four criteria that are based on the project goals, objectives, constraints, as well as customer requirements. The four criteria are cost, weight of modification, noninvasiveness, and safety.

- ◆ **Cost:** Although the cost was not one of the most important of customer requirements it is a defining constraint of the project, which is why it was chosen as one of the criteria for the design selection.
- ◆ **Weight:** The HOQ shows that the weight is not one of the most important engineering characteristics, however too heavy of modifications would increase the strain on the batteries and in turn reduce the overall performance of the vehicle. Since improving the performance/increasing the range is one of the project objectives the weight was chosen as a design selection criteria.
- ◆ **Noninvasiveness:** This selection parameter was chosen primarily due to the project time constraint of two semesters. The more complex the design is the more time it will take to develop, therefore it was decided that the simplest solutions would be the best.
- ◆ **Safety:** One of the two most important customer requirements was the safety of the design therefore it is an important selection criteria.

A “+” indicates that the particular aspect is superior to the datum, a “-“ indicates that it is inferior to the datum, and an “S” indicates that the option is neither better nor worse. The total number of minuses was subtracted from the total number of pluses to obtain the score of the solution concept, with a positive score being the most favorable.

### 3.2.2 Generator Location

One possible location for the generator is under the back seat of the golf cart, as seen in Figure 3 on the following page. The generator would be placed in this recessed region and would be mounted to the golf cart frame that runs under the rear seat and under the black plastic flooring. Figure 3 also shows another possible solution, which is that the rear seat could be removed and the generator mounted in its place. This of course eliminates the functionality of the rear seat which is not desirable. The third and final solution concept is that the generator could be placed on carriage, similar to that pictured in Figure 4, that would be pulled behind the cart. This solution presents a safety issue as the carriage could fishtail and potentially cause an accident.



**Figure 3. Photograph of the back of the golf cart.**



**Figure 4. Carriage design concept. [4]**

Table 1 is the Pugh matrix for the generator selection, and it shows that the best location for the generator is under the back seat with a score of 0 as compared to -4 and -1 for options 2 and 3, respectively. Not only is this solution the least invasive, it is also the safest because it is well secured and is well separated from the user.

**Table 1 Generator Location Pugh Matrix**

Criteria	Under Back Seat	On a Carriage	In Place of Back Seat
Cost	S	-	S
Weight	S	-	+
Noninvasive	S	-	-
Safety	S	-	-
Total	0	-4	-1

### 3.2.3 Battery Warming Method

Another sub-problem is the method of heating the battery up to an operable temperature. A possible solution is to use the generator exhaust to heat them. This solution would involve the

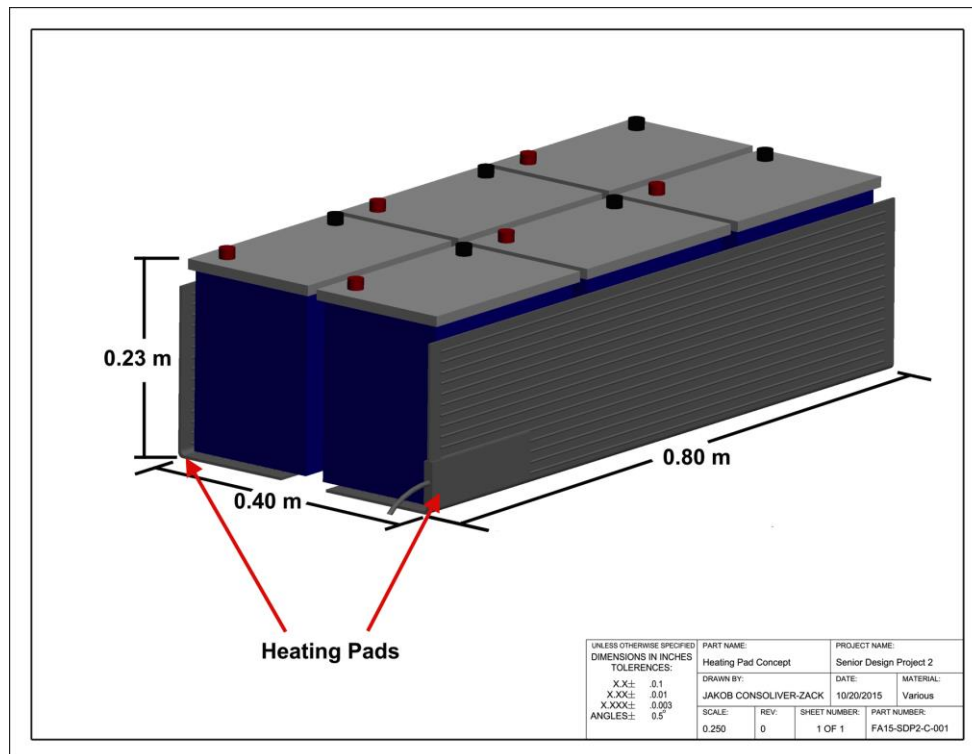

**Figure 5. Heating pad design concept.**



design of a system of tubing to maximize the amount of heat transferred from the exhaust to the batteries. Careful time intensive design would be needed with this solution so that the exhaust does not melt the battery casings. Another possible solution is the use of heating pads, which would be attached to the surface of the batteries, as seen in Figure 5 on the previous page. The last solution to this sub-problem is to encase the batteries in an insulating material. This method is the simplest of the three, however it is not as effective as the other two since the heat in the batteries will eventually dissipate given enough time.

The Pugh matrix for the selection shows that both the heating pads and the insulation are both better than using the exhaust. Although the heating pads and the insulation scored equally well, based on the selection criteria, it was decided to go with the former since it would be more effective due to the previously stated reasoning.

**Table 2 Battery Heating Method Pugh Matrix**

Criteria	With Generator Exhaust	With Heating Pads	With Insulation
Cost	S	+	+
Weight	S	+	+
Noninvasive	S	+	+
Safety	S	+	+
Total	0	+4	+4

### 3.2.4 Ensuring Generator Operation

The third problem to be solved is how to ensure that the generator would operate in subzero conditions. After speaking with Dr. Hollis about this matter he informed the design team that the most likely modes of failure would be an improper air-fuel ratio, the battery powered ignition system not operating, and the oil becoming too viscous. Although the specific choice of generator had not been decided when developing these design concepts it was known that the generator would be from Cummins. The vast majority of Cummins generators designed for mobile applications and recreational vehicles include an automatic choke, eliminating the first problem. Additionally the generators are also rated down to  $-29^{\circ}\text{C}$ , which eliminates the second issue, leaving only the oil viscosity problem. [5] One possible solution is to use a synthetic oil that is rated down to the subzero temperature required. The other two solutions involve heating

the oil with a device such as an oil dipstick heater or an oil pan heater. These two options however require a power source and present a safety hazard due to the high temperatures that they operate at. The Pugh matrix below shows that the best option is to use synthetic oil.

**Table 3 Ensure Generator Operation Pugh Matrix**

Criteria	Use Synthetic Oil	Use an Oil Pan Heater	Use an Oil Dipstick Heater
Cost	S	–	–
Weight	S	–	–
Noninvasive	S	–	–
Safety	S	–	–
Total	0	–4	–4

### 3.2.5 Charging System

The final sub-problem is the charging system that the golf cart will use. One of the primary objectives of the project is to have the generator activate when the battery charge drops below a certain level. At present the cart is equipped with a delta Q QuiQ Model: 921-48xx AC to DC charger. The charger works by supplying the batteries with power until it detects no increase in the voltage; meaning they are fully charged and the charger shuts off. This presents a problem since an objective is to run the vehicle and charge at the same time. The rate at which the batteries are charged is less than the rate at which they are depleted, which means that the battery voltage will be slowly decreasing. The charger would then detect that the batteries are full and would stop even though they are not at full capacity. The second solution is that a new charging system would be designed. This solution would use a new on-board charger that uses a different mechanic that allows the voltage to decrease yet continue charging. The third option would be to modify the present charging system. This would be cheaper than developing a new system, because the currently equipped charger would be reprogrammed to meet the design needs. The problem with this solution is that the reprogramming poses a safety risk as various safety features could inadvertently be overridden. All three of the solutions would include a micro-controlled system that would activate/deactivate the generator based on the measured voltage of the batteries. The Pugh decision matrix on the following page indicates that the third solution – modifying the present charging system - is the best of the three.

**Table 4 Charging System Pugh Matrix**

Criteria	Use Present Charging System	Develop New Charging System	Modify Present Charging System
Cost	S	–	–
Weight	S	S	S
Noninvasive	S	S	+
Safety	S	+	+
Total	0	0	+1

After doing further research on how the charger works and weighing options on how to actually modify the present charging system, it was determined that a new method for modifying the way that the present charger interacts with the golf cart's batteries would have to be formulated. This was decided in order to avoid any potential issues involving the operator's safety and potentially damaging any of the cart's onboard electronics systems or the batteries themselves. The new method that would be chosen for the golf cart will be discussed in the next section.



providing power to the motor. This is because the charging system only provides charge if it sees that the voltage of the system is increasing. In order to meet the project objectives the initial system design concept was revised. The revised initial design uses the generator to charge the golf cart's batteries and supply power to the cart's motor and electrical systems. The cart batteries are disconnected from the motor by using the relays, as seen in Figure 6. This would allow simultaneous operation of the cart and charging of the batteries. And of course, when the battery is charged and at the operating temperature, the system could revert back to being solely battery powered at the switch of the generator's and charger's relays.

## 4 Final Design

The final design developed differs slightly from that defined in the concept generation section. The largest difference is how the system recognizes that the batteries require charging. As was initially planned the charge of the batteries would be determined from their measured voltage, however this method was met with complications. When the batteries are loaded by running the motor, turning on lights, etc. there is a drop in their voltage. When the accelerator pedal is fully pressed there is a voltage drop of approximately 2V. This drop "tricks" the system into thinking the batteries require charging and proceeds to activate the generator to charge them even if they don't require it. To prevent this issue the system was redesigned so that the user activates the generator, via a switch. The user will know when to activate this switch based the golf cart's onboard visual battery meter. This solution was developed at the sponsor's suggestion. Unfortunately this does mean that the initial goal of automatically starting the generator when the batteries require charging will not be met. Developing a method to accurately measure the state of charge of the cart's batteries is something that could be developed by future senior design teams. Despite this change and other minor modifications the major components of the design remain the same. Many of the parts in Figure 6 as well as additional minor components can be categorized into one of four sub-systems, which include the Power System, the Control Circuit, Auxiliary Loads, and Sensor Inputs. The mechatronic programming, the mounts fabricated for the various components, and the electrical mountings are also important aspects of the design.

## 4.1 Major Systems

### 4.1.1 Power System

As its name implies the power system involves which device(s) power the golf cart's 5,000W DC motor and other electrical systems [6]. A simple circuit diagram of the power system is given in Figure 7.

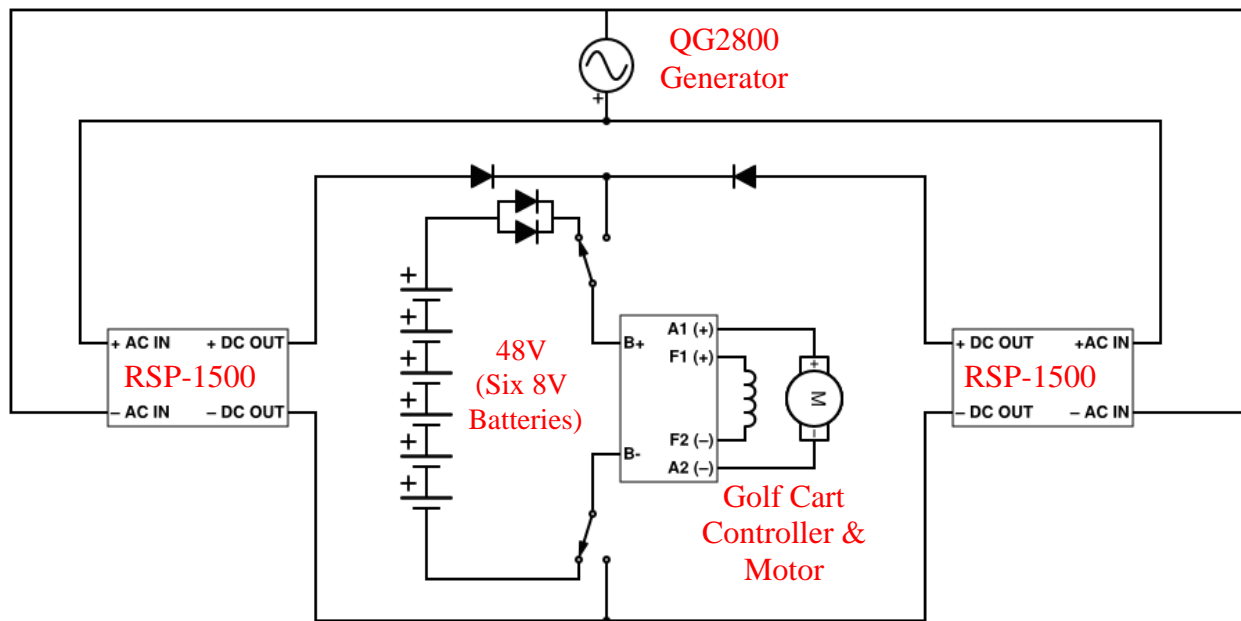

**Figure 7. Power system circuit. The relays are represented by the arrow and dot configurations.**

The two possible motor power sources are the cart's six 8v lead acid batteries and a Cummins QG2800 Generator. The generator outputs a maximum of 20.8A @ 120 V<sub>ac</sub>, however the motor is DC, so two RSP-1500 48V power supplies are used to convert the generator output into the necessary motor input [7]. The maximum input to the motor is approximately 2,275W, which corresponds to 47A @ 48V<sub>DC</sub>. The motor power source is controlled via two high power double pole double throw relays with a 150A maximum continuous duty rating [8]. These relays are controlled by a Ruggeduino microcontroller. When the relays activate during operation there will be a voltage spike that could potentially damage the power supplies and/or batteries. In order to

prevent this both the battery and power supply outputs are routed through two RHRG75120 high power diodes with a maximum rating of 75A @ 1.2kV. The diodes in line with the batteries have begun to show visible signs of use. As such it is recommended that they be replaced with higher rated diodes such as with two APT30SCD120B diodes.

#### 4.1.2 Control Circuit

The control circuit is the heart of the design as it is responsible for controlling power distribution through the system. A schematic of the control circuit is given in Figure 8:

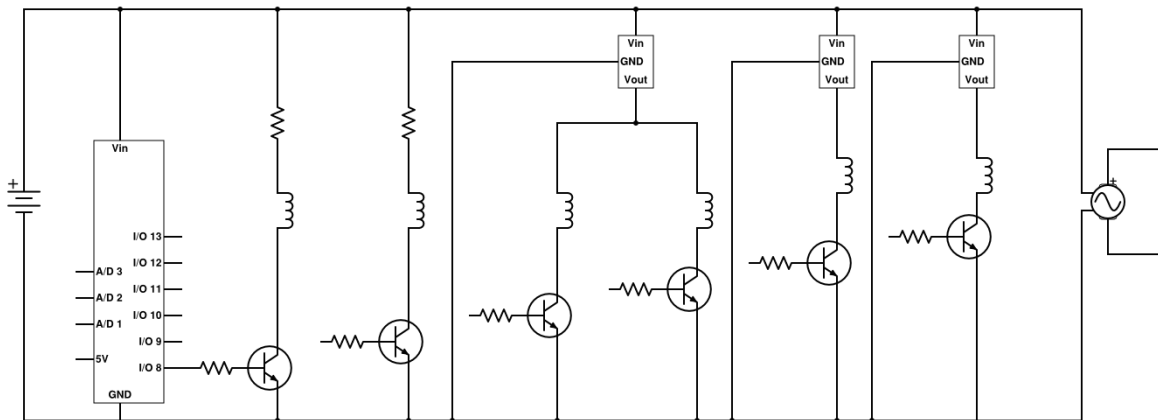

**Figure 8. Circuit diagram of control circuit. The relay control coils are represented by the inductors. The leftmost box is the microcontroller while the three leftmost boxes are voltage regulators to limit the coil voltage to 12V, even when the alternator is charging the generator battery. The generator is represented on the far right.**

The control circuit consists of a system of transistor-relay pairs that are activated by the Ruggeduino microcontroller. The relays in the design control the activation/deactivation of the generator, the motor's power source, and when power is supplied to auxiliary loads such as the cart's on-board charger and the installed heating pads; these latter two components will be addressed later. When a relay needs to be activated a corresponding pin on the microcontroller applies a voltage to the base of the connected transistor allowing current to flow across it. As can be seen in Figure 8 the relay coil is connected in series to an NPN transistor so that when the transistor is activated the relay coil is energized flipping the relay load switch. All of these relays as well as the Ruggeduino itself are powered off of the generator's 12V battery. In addition to controlling the relays the Ruggeduino is also responsible for powering the sensors as well as

reading their respective outputs. The details of these sensors are outlined in the following section.

### 4.1.3 Input From Sensors

As previously mentioned the system will monitor the battery voltage and temperature. The voltage is monitored using a voltage divider that proportionally scales down the sum voltage of the cart's batteries to a voltage that the microcontroller can safely measure. The Ruggeduino then uses this value to calculate the actual voltage of the batteries. Due to the simplicity of this monitoring method there is little chance of hardware failure. Unfortunately this method does have flaws. As previously mentioned the battery voltage drops when they are loaded so their voltage is not a good indicator of their state of charge; except when the batteries are not loaded (i.e. when the cart is off). Future senior design groups could better develop a method for determining the batteries state of charge. The temperature is monitored using a TMP36 temperature sensor that is placed near the battery terminal connected to the motor. Unfortunately the TMP36 was damaged during soldering and requires replacement. Until the sensor can be replaced it was set to a constant value around room temperature. In addition to the voltage and temperature monitoring the output current of the charger is also monitored using a DFRobot 50A Current Sensor. The current is monitored in order to confirm that the batteries are being charged and to know when they are done being charged. The measured current is a critical parameter that has a significant effect on the operation of the installed system, due to how the software on the microcontroller was programmed.

### 4.1.4 Auxiliary Loads

The auxiliary loads in this design are the cart's onboard 1200W QuiQ 912-48xx charger and the two Zerostart 160W heating pads [9-10]. Both the charger and heating pads run off of AC power so they are connected in parallel to the generator output, as they do not need to be converted to DC via the power supplies. A circuit diagram of their configuration is given in Figure 9 on the following page. The load ends of the relays used to control the charger and heating pads are connected to the positive AC input wires of the respective devices. Additionally



the current sensor is placed in line on the chargers positive output wire.

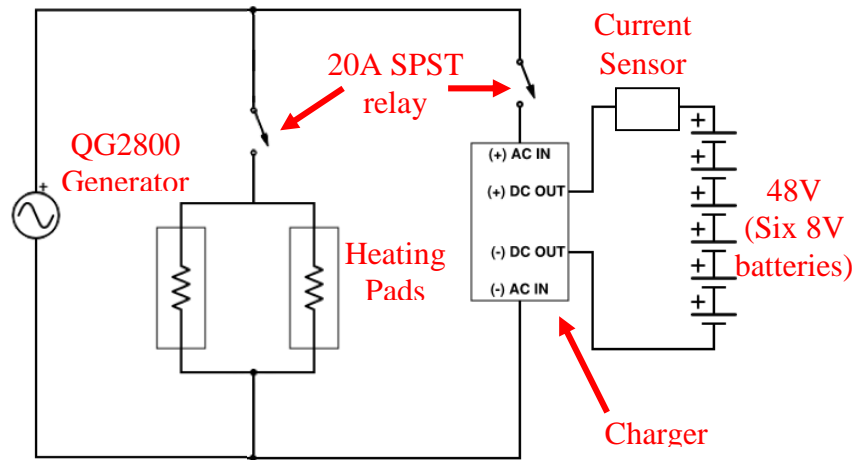

Figure 9. Heating pads and charger circuit.

## 4.2 Mechatronic System

In order to meet the objectives a mechatronic system consisting of four possible states was developed. Depending on the charge and temperature of the golf cart batteries the system will be in one of these four states. Below is a state diagram which shows each state as well as how to get to and from each state. When the batteries are charged and their temperature is

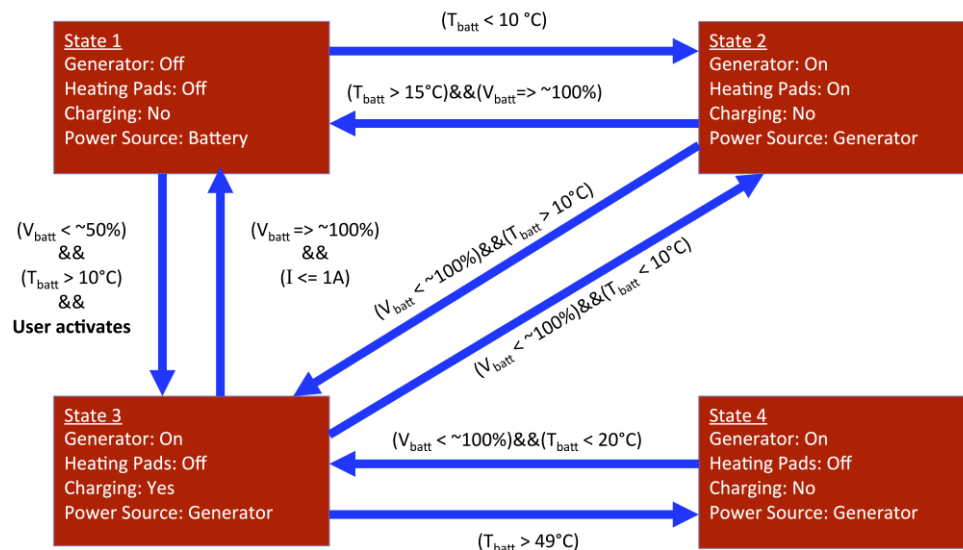

Figure 10. State diagram of mechatronic system. The states are represented as red boxes and the requirements to transfer between states are given by the blue arrows.

between 10°C and 49°C on startup the system will be in state 1. This is the normal operational state of the mechatronic system and is the default startup state. In the event that the batteries do not require charging but they are too cold to safely operate the system will be in state 2. In this state the generator is on and powering the heating pads as well as the motor. Because the generator can only output 2,500 W the maximum speed of the golf cart in this state will be reduced. When the temperature of the batteries exceeds 15°C the generator will turn off and the system will transition back to state 1. If the batteries charge drops below 50% and are sufficiently warm enough the system will transition to state 3 upon activation of the generator by the user via a switch. Again the use of this switch was necessitated due to the flaws in the charge monitoring system. In this state the generator is on and is powering the on-board charger and the motor. As was the case in state 2 the maximum speed in this state is also reduced. When the batteries are charged to 100%, determined by 0A charger output current, the system will again transition to state 1. The final state of this mechatronic system is state 4, which is the failsafe state of sorts. If at any time the battery temperature exceeds there maximum safe operating temperature of 49°C the generator will kick on and power the motor. Since the batteries are too hot the generator will neither heat nor charge them and will simply power the motor. When the batteries cool down below 20°C they can then again be used to power the motor at which point the system will transition to whatever state is required. The code developed and loaded onto the Ruggeduino is given in Appendix A.

## 4.3 Design for Manufacturing

### 4.3.1 Mount Fabrication

The mechatronic design utilizes a QG 2800 Cummins generator to power the golf cart when the batteries need charging. This generator is fueled by propane and utilizes a 12 volt battery to operate. Mounts for each of these components were fabricated to ensure they are secure on the golf cart.

#### 4.3.1.1 Generator Mount

The generator and propane tank mount was fabricated out 2 in x 2 in x 1/8 in steel angle iron. The generator mount is composed of two U shaped brackets and two support pieces. With a

U shaped bracket bolted to each side of the generator with 3/8" bolts. Each U shaped bracket is connected to a piece of steel angle with two 3/8" bolts. This steel angle runs across the rear seat support ensuring that the generator is secure under the back seat. Figure 11 below shows a photograph of the generator mounted to the cart.



**Figure 11. Photograph of generator mount.**

#### 4.3.1.2 Propane Tank Mount

The propane tank mount was designed to mount to the rear hand-rail that hangs off the back end of the cart, as seen in Figure 12 on the following page. Utilizing the steel angle iron that was purchased for the generator mount, the team designed a mount to securely fasten the propane tank to the back of the cart. This design also allows for easy removability of the tank. The mount is secured to the golf cart's frame with four 3/8" bolts. Protective material was added to the mount to ensure the metal does not rub against the tank and possibly cause sparks while in motion.



**Figure 12. Photograph of the propane tank mount.**

#### 4.3.1.3 Power Supply Mount

These power supplies as well as the 12 volt generator battery are mounted in the golf cart's battery compartment underneath the front seat. The housing, see Figure 13, for the power

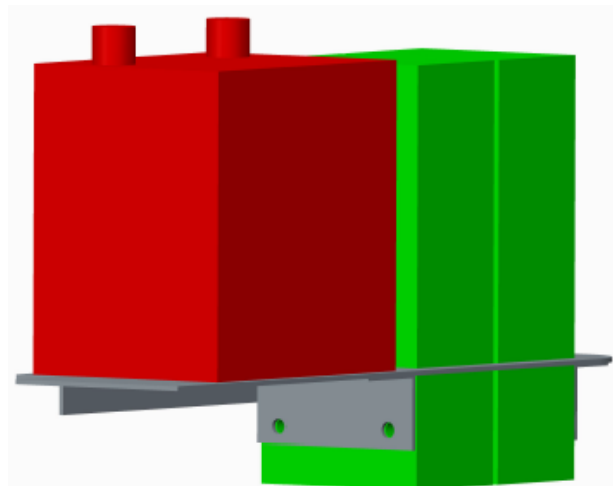

**Figure 13. Assembly showing how the power supplies (green) are fastened to the plate and how the battery (red) rests on the plate.**

supplies and generator battery was constructed using steel sheet metal that was cut to fit in the region between the cart's six 8V batteries and the wall of their enclosing compartment. A portion of the metal was cut out to allow the power supplies to slide into the plate. Brackets were added to secure the supplies to the housing. Additionally the supplies are joined together with steel strips, one on either side, that are bolted to the supplies with M4 screws, as seen in Figure 14 below.

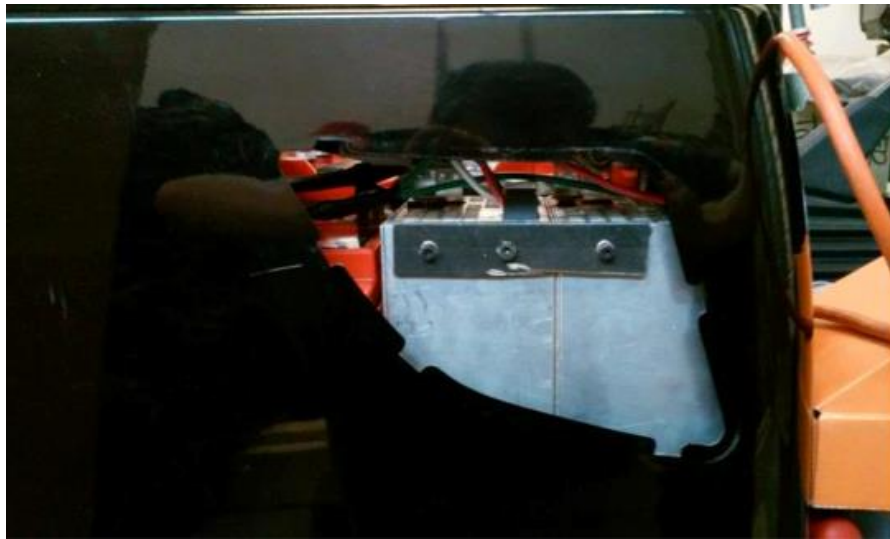
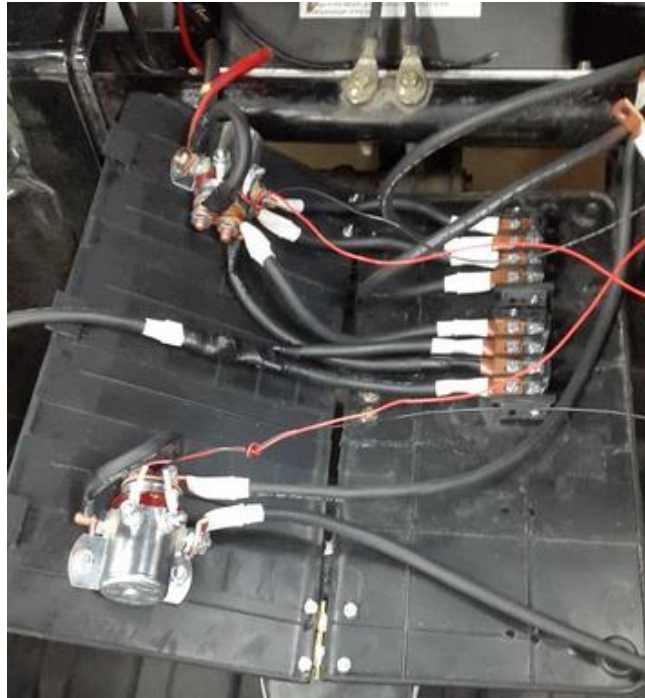

**Figure 14. Power supplies fully mounted in cart.**

## 4.3.2 Circuit Mounting

### 4.3.2.1 Circuit

A majority of the circuit was composed of 2 gauge wire with crimped on ring connectors. These wires run from the two AC to DC power converters to two relays as seen in Figure 15 on the following page. From the relays, the power runs to two terminal blocks and then to the golf carts motor. The diodes used to regulate inductive kickback are mounted directly to the positive side terminal block. The majority of this circuitry is routed between the rear of the cart to the middle of the cart lying in the body. This area stays dry and wire straps were used to fasten the wires to the cart.



**Figure 15. Access panel with the motor relays and terminal blocks mounted to it.**

#### 4.3.2.2 Relay Location

The motor relays shown above in Figure 15 are mounted on an access panel located on the rear of the cart, as indicated in Figure 16. This spot allows for quick and easy access while also keeping them protected from outside elements such as water. Additionally the mounting of

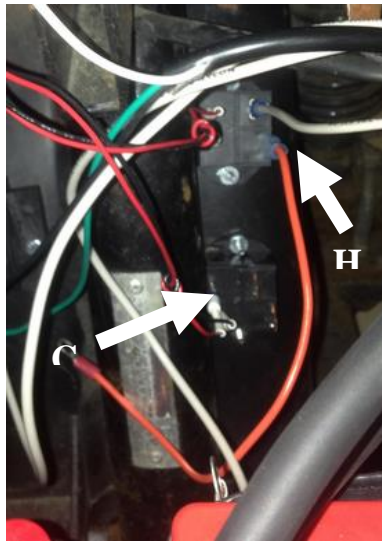

**Figure 16. Photo of the access panel.**



the components on this plastic panel keeps them insulated.

Electrical equipment is very fragile thus it was very important to mount the relays in an area that will stay dry and clean. The charger and heating pads relays were mounted in the compartment below the front seat. They were fastened to the rear passenger wheel well using bolts and nuts, as seen in Figure 17 below. Additionally there is empty space around them making them relatively easy to access.



**Figure 17. Heating pad (HP) and Charger (CH) relay location.**

The generator requires one relay to activate it and another to turn it off. These relays were mounted on the back side corner of the generator, attached directly to the generator's green housing. This location can be seen circled in Figure 18, below. The location of the relays

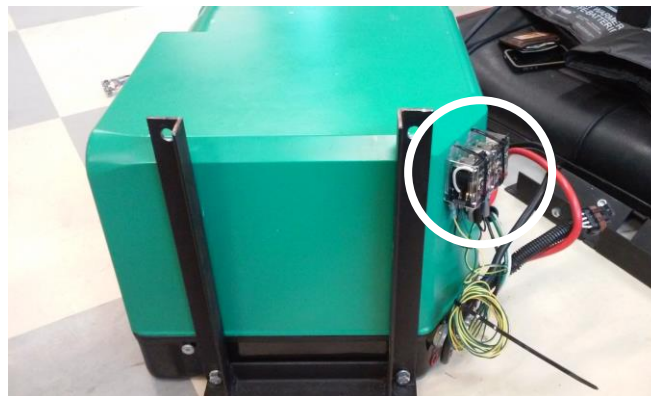

**Figure 18. Generator with the relay location circled.**

allows for easy access and ensures the relays will not be open to the elements.

#### 4.3.2.3 Sensor Location

The mechatronic system includes two sensors, a current sensor and a temperature sensor. The temperature sensor is mounted on top of the golf carts batteries near the positive terminal. The current sensor is mounted under the front seat on the golf cart controller housing as seen in Figure 19 below.



**Figure 19. Photograph of where current sensor, circled, is mounted.**

#### 4.3.2.4 Microcontroller and LCD Display

Due to a recent setback, leaking 8 volt battery, we have not finished testing the carts system. Having the LCD display in an easily accessible area will allow for easy testing of certain systems, therefore a permanent spot has not been selected. For the microcontroller, we plan on mounting it in a tupperware container. This will guarantee that no water, dust and other contaminants will be able to come in contact.

### 4.4 Design for Reliability

A very important aspect of the design of this system is the reliability of the system and its various components. There are many different portions of this design that must interface with one another in order for the system to function as intended. As such, it is a necessity to ensure that the system can function reliably in order to minimize downtime and be used without any



hindrances. There are mechanical and electrical subsystems that include the generator, DC motor, various transistors, diodes, relays, and the batteries that power the electronics that must interact with one another continuously to provide a trouble free experience. As such the reliability of these systems needed to be taken into consideration in the design of the system.

#### 4.4.1 Factors of Safety

One of the most critical portions of the design is the various relays, transistors, and diodes that make up the electrical subsystem. If these components are not able to tolerate the loads that the design will subject them to, then the system will not be able to function as intended. Therefore, it's very crucial to know that these components are able to withstand the current that they will be loaded with.

##### 4.4.1.1 Relays

The relays in the system regulate power distribution to the various components. In order to make sure that the relays would be able to function as intended, the safety factors for each were calculated by taking the current that the relay was rated for and dividing that by the current that would be flowing through it. As long as this safety factor is above one, then the relay should be able to consistently be used without damage and the higher the value, the better the amount of safety built into the system. The relay controlling the heating pads has a safety factor of five. The charger relay that controls the charger circuit has a safety factor of two. Lastly the relays that are completing the circuit between the cart's batteries and the motor are rated at a safety factor of four. Thus, all of the team's relays should be more than capable of seeing the sustained current levels that will be distributed amongst them.

##### 4.4.1.2 Transistors

Another important component of the system's circuitry are the various transistors which are used in order to switch signals and amplify currents in order to allow equipment with different operating currents to be connected. In order to calculate the factors of safety on the various transistors, a similar approach was taken to that which was done for the relays. The current that the transistor is rated for was divided by the current that the transistor would actually see and that calculated value was taken as the factor of safety. Since there is 12 volts through the

transistors and the resistances of each are known, the current was simple to calculate by dividing the voltage by the resistance of each transistor. The transistor for the heating pads and charging system have a factors of safety of 2.7. The generator circuit transistor has a factor of safety of 1.7. And lastly the transistor for the power supplies has a factor of safety of 5.8. Therefore, all of the transistors are able to meet the demands of the design and will be able to operate reliably at the current levels of the system.

#### 4.4.1.3 Diodes

Diodes are installed in the system in order to keep the current from flowing backwards and thus allowing for the two power supplies to be connected in parallel without interfering with one another. The same convention was used as before with current as the measure to account for the factors of safety. In the end, the two diodes were rated with a factor of safety of 1.4. Additionally due to the possibility of inductive kickback during power switching diodes capable of withstanding 1.4kV were selected. Despite the factor of safety **the diodes connected to the batteries showed visible signs of use so it would probably be best to replace them with higher rated diodes, such as an APT30SCD120B diode, before continued operation.**

#### 4.4.2 FMEA

In addition to using factors of safety to ensure reliability FMEA was conducted in order to determine the possible ways the system could fail and how their failure would affect the system. Table 5 on the following page is a compilation of this analysis. The main reliability concerns over the system's various components were each placed in the first column. The second column consists of the potential failure modes of the system, which are essentially the different ways that the system components can fail. The third column further expounds upon the failure modes with the potential effects that can occur from the failure mode. The fourth column details the severity of the aforementioned failure mode and its effects on a scale consisting of low, medium, and high ratings. Lastly, the fifth and final column lists all the possible causes for the failure modes.

**Table 5. FMEA of design components.**

Team Number	2			
Project Description	Improving the range of an electric vehicle			
Component	Potential Failure Mode	Potential Failure Effects	Severity	Potential Causes
What is the primary component affected?	In what ways can the component fail?	What is the impact of this failure mode?	How severe is this failure to the user? (Low, medium, high)	What causes the component to fail?
Heating pads	Not activating	Batteries will not be heated in cold climates	Medium	Loose wire Inaccurate/no temperature sensor reading
	Remaining active	Heating pads will stay on Might overload the generator if charger is active	High	Damaged transistor
Charger	Not activating	Batteries aren't receiving a charge	High	Loose wire Lack of power from generator
	Remaining active	Charger remains active, but won't overcharge batteries	Low	Damaged transistor
Generator	Not starting	Generator is inactive, but the system will still switch to generator powered state	High	Loose wire Low/no oil No/poor propane connection Insufficient battery charge Circuit breaker tripped
	Won't shut off	Generator will remain on unnecessarily, potential damage to generator	Medium	Damaged transistor
Power supplies	Not activating	Power supplies will be inactive	High	Loose wire
	Remaining active	Power supplies will remain active, potential damage to power supplies	Medium	Damaged transistor
Microcontroller	Not activating	System isn't switching states	High	Installation error Improperly code Damaged pins Sensor error
Temperature sensor	Not giving accurate temperature readings	System will incorrectly switch states	High	Manufacturing defects Improperly coded Installation error
Current sensor	Not giving accurate temperature readings	System will incorrectly switch states	High	Manufacturing defects Improperly coded Installation error

### 4.4.3 FEA

A focal point of this design is the integration of the generator with the golf cart and its electrical systems. As such, it was important to ensure that the generator was safely mounted to the vehicle in a manner that would allow easy access and also keep the generator attached when the cart was in motion. As can be seen in Figure 20, the final generator mount design can be seen

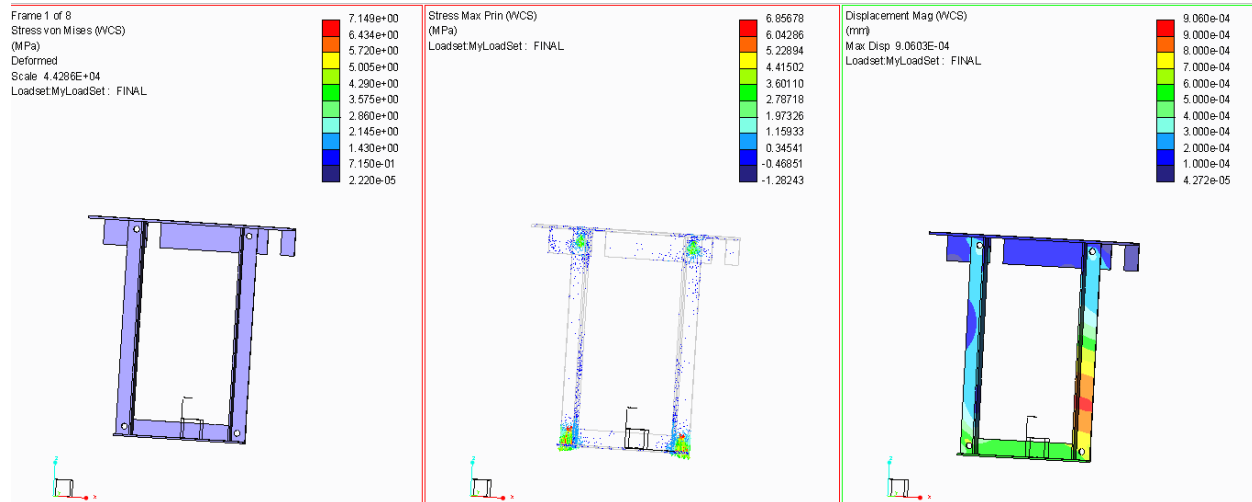

**Figure 20. FEA conducted on generator mount.**

along with the stress and displacement analysis that was performed on it. Here it can be seen that the stresses on the mount are minimal with the greatest concentration of stresses being at the joints where the mount's individual pieces are connected. However, even this maximum stress is negligible and is not a cause for concern over the reliability of the mount.

### 4.4.4 Reliability Summary

The reliability of any system is an important aspect that should be heavily analyzed in order to have a successful design that functions as intended. After considering this and designing the circuitry and mechanical components in a manner that will allow reliable operation of the golf cart, the prototype will perform as intended from the first time to an undetermined number of cycles. The total life span of this system has not been determined due to lack data on the lifetime of various components including the on-board charger, power supplies, as well as the various preexisting components in the golf cart. Despite this the best design efforts were made to

select components with a high factors of safety so they can operate over many cycles of use without any ill effect.

## 4.5 Operation Instruction

### 4.5.1 Starting the System

Due to the passive nature of the design operating it is quite simple as the majority of the processes are conducted by the system automatically. In addition to the instructions detailed in this section please consult the golf cart's manual for additional safety and operational instructions. **Before activating the system please ensure the following are true:**

1. The golf cart key is turned to the OFF position.
2. The FORWARD/REVERSE switch is in the NEUTRAL position.
3. The parking brake is on.
4. The cart's TOW/RUN switch is set to the RUN position.
5. The propane tank is secured to its mount.
6. The propane tank connections are secure and the valve is open.

If all of the above criteria are true the system can be safely activated. The systems ON/OFF switch is located in the center of the cart between the front and rear seats. To activate the system simply turn the switch to the ON position. When the system activates you should hear audible clicking, which indicates that the various relays in the system are functioning properly. If the batteries are too cold the generator will activate. If the batteries are fine in terms of temperature the cart will continue to operate off of battery power. An LCD screen located on the dashboard will display the voltage of the batteries as well as their temperature. In addition if the batteries are being warmed, charged, or have overheated this will also be displayed on the screen as the state. Once you are ready to drive the cart follow these steps:

1. Turn the golf cart key to the ON position.
2. Set the FORWARD/REVERSE switch to the desired setting.
3. Release the parking brake.
4. Drive

### 4.5.2 During Operation

Due to the generator outputting less than what the motor requires to fully power it the cart will have a reduced maximum speed of about 6 mph when operating off of generator power. The battery charge indicator located on the dashboard will show the charge level of the batteries. When their charge drops below acceptable levels press the charge button, the left one, on the dashboard. This will activate the generator and begin charging the batteries. If the cart is moving faster than this speed when the charge switch is activated the generator could be overloaded. So as not to damage the system, reduce cart speed to less than 5mph before activating the charge switch. For the best results and to further extend the lifetime of the system bring the cart to a complete stop before activating the switch.

### 4.5.3 Stopping the System

In the event that the automatic activation of the generator is not desired or if the cart is going to be stored for an extended period of time the system can be deactivated.

If the generator is **OFF** when attempting to deactivate the system follow these procedures:

1. Turn the golf cart's key to OFF position
2. Set the FORWARD/REVERSE switch to the NEUTRAL position
3. Ensure the parking brake is on.
4. Turn the systems ON/OFF switch to the OFF position.
5. Close the propane valve.
6. Set the cart's TOW/RUN switch to the TOW position.

If the generator is **ON** when attempting to deactivate the system follow these procedures:

1. Turn the golf cart's key to OFF position
2. Set the FORWARD/REVERSE switch to the NEUTRAL position
3. Ensure the parking brake is on.
4. Turn the systems ON/OFF switch to the OFF position.
5. Press the generator OFF button, right button, located on the dashboard
6. Close the propane valve.

7. Set the cart's TOW/RUN switch to the TOW position.

If at anytime during the operation of the cart the system fails in some way reset the system by turning the generator off, if it is on, and then turning the systems' switch from ON to OFF> Following these steps proceed to follow the operation instructions for activation.

## 5 Systems Testing

Due to the complexity of the electrical system it was decided to test the various components individually before assembling them all together. The tests performed are outlined in this section.

### 5.1 Transistor-Relay Test

As previously mentioned the control circuit consists of a relay and transistor connected in series. In order to ensure that this configuration would work the ability of the transistor to activate the relay was first tested. This was done by applying 12V to one end of the relay coil and attaching the collector end of the transistor to the other end. The transistors emitter was connected to ground and the base to a resistor that in turn was connected to a Ruggeduino I/O pin. This pin was then set to from low to high and an audible click was heard from the relay indicating that the configuration worked.

### 5.2 Power Supply Test

A large portion of this design is dependent on the power supplies converting the generators AC output to the DC input required by the motor. This system was tested by connected the power supplies in parallel and attaching their combined output directly to the golf cart controller. Of course the batteries were detached from the golf cart during this testing. The power supplies were plugged into a standard wall socket for initial testing. The rear wheels of the cart were then raised from the floor via jack and the cart was turned on. The headlights and other minor electrical systems were activated to ensure operation when operating off of generator power. Following this successful test the accelerator pedal was pressed causing the rear wheels

to spin. This showed that the power supplies could in fact power the system. This test was performed again with the power supplies attached to the generator output instead of a wall socket. Additionally following the successful retest the rear of the cart was lowered and the cart was driven solely off of generator power.

### 5.3 Power Switching Test

Following the successful testing of the power supplies the ability of the system to change motor power sources was tested. The power circuit shown in Figure 7 was constructed and wired into the cart. The cart was then turned using the batteries to power it. The Amtek relays were then activated and the system successfully switched over to generator power.

## 6 Considerations for Environment, Safety, and Ethics

Any application dealing with potential environmental hazards must take extra precautions to ensure safe operation. A major aspect of this project involves six lead acid batteries. Lead acid batteries consist of lead plates that are submerged in a sulfuric acid, and these components are contained by a polypropylene plastic casing. The plastic casing is there to protect anyone using lead acid batteries from the potential risks of the materials inside. [11] Lead, a major material in the batteries, is a highly toxic metal and has been linked to a range of health conditions due to absorbing it. Lead poisoning can cause learning disabilities, behavioral issues, or in extreme cases can cause seizures. [12] The other main component to the battery is sulfuric acid, again a highly corrosive solution. This acid can cause burns to the skin or irritation to the upper respiratory system. [11] Since these materials are highly toxic, proper disposal is crucial to the environment. If these batteries were disposed in a traditional waste landfill, the toxic chemicals can seep into the soil, causing potential risks to drinking water and surrounding land. Some safety measures are taken when disposing of these batteries. When buying a new car battery, retailers will take your old one and properly dispose of it. Scrap metal dealers also collect old lead acid batteries. When the batteries are properly disposed, they go through a recycling process. The lead plates and plastic cover can be recycled and used for new batteries and the sulfuric acid is neutralized. [11]



During the assembly of the cart one of the batteries cracked and began leaking acid on the floor. All work was immediately stopped and efforts were redirected toward cleanup. The leaking battery was put into a bucket that was then placed outside so that possible fumes would not endanger the team members. The liquid was cleaned up with paper towels while making sure to use protective gloves when handling the used towels. In order to neutralize the remaining acid baking soda was sprinkled on the floor and allowed to sit for about 10 minutes. The baking soda was then swept up. This process was repeated one more time to ensure all the acid had been neutralized. The damaged battery itself was returned to the local supplier to be disposed of. No team members were harmed during this incident.

Another potential environmental hazard for this project includes the emissions of the propane powered generator. Portable generators cause a risk by emitting carbon monoxide, which is a highly dangerous gas if inhaled. [13] These portable generators have been recommended to only be used outside due to this emission. However, certain codes have been enforced to any machine that emits a gas, to reduce this toxic waste. To ensure safe operation the generator selected for this project has been approved and meets the U.S. EPA standards for emissions.

## 7 Project Management

### 7.1 Schedule

In order to ensure that a design that satisfied the objectives could be developed assembled, and tested in only two semesters it was necessary to outline a schedule. The Fall semester dealt primarily with the developmental stage of the design. This included defining the project scope as well as generating design concepts. A large portion of the mechatronic programming and control circuit design was done during the last half of this semester. The Spring semester involved additional design development, but also the assembly and testing of said design. For both semesters the scheduling/project-timeline was done using Gantt charts. The Gantt charts for the Fall and Spring Semesters can be found in Appendix B. For the most part the Gantt chart was followed however unexpected delays such as having to replace broken

components did cause some delays. These delays were primarily in the Spring Semester and are why the project is currently about a week behind schedule. The expected completion date was 4/4 however due to delays the new completion date is set for 4/10.

## 7.2 Resources

Due to the size of the golf cart it was not possible to store it in the senior design room. With the permission from both Dr. Nikhil Gupta and Dr. Emmanuel Collins the cart was stored in the Ciscor lab at AME for both semesters. Additionally the ME mechatronics labs and EE labs were used during circuit design and testing. The advice and assistance from both Dr. Gupta and Dr. Camilo Ordonez was quite helpful during the design of the various circuit systems. Lastly rather than use the machine shop to make the necessary mounts one of the team members used their own equipment, which saved time on assembly. Any resource that was available to the team was fully utilized.

## 7.3 Procurement

### 7.3.1 Budget Breakdown

Cummins provided the ME budget of \$2,000 to generate a proof-of-concept design to model the "hotel system of charging". Team 2 has been working with an independent team of

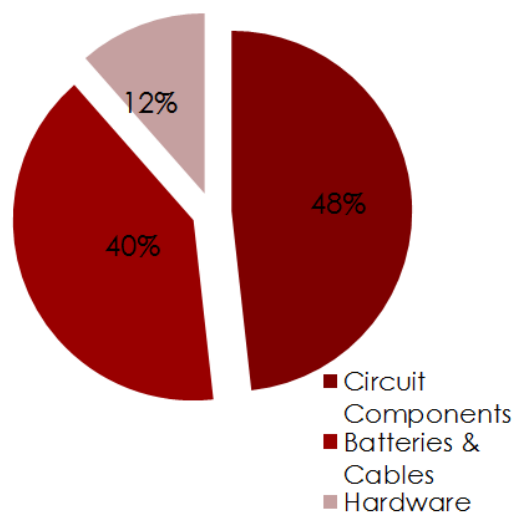

**Figure 21. Pie chart of budget breakdown.**

electrical engineers, which the Electrical Engineering department provided a \$800 budget.

This budget was broken down into three main components. The circuit components include all of the necessary parts to build the circuit for the mechatronic design. This includes the microcontroller, and various wires, diodes, and resistors that were utilized. As well as the relays that will be turning on and off the generator, power supplies, etc.. The heating pads to warm the batteries also fall under the circuit components. A LCD screen was purchased to ensure easy programming and to ensure the monitoring system is user friendly. The various parameters such as voltage, current and temperature are displayed on the screen, as well as the state at which the cart is in. A replacement Delta Q charger for the cart was also purchased because the one that was received with the cart did not work.

The batteries that were received with the cart had been sitting for too long and had crystalized, therefore the team had to purchase six 8 volt lead acid batteries to replace the old ones. The team of electrical engineers purchased three while the mechanical engineers purchased the remaining three, as well as the replacement for the cracked battery. The 12 volt battery for the golf cart is also included in the batteries purchased, as well as the cables to connect the terminals.

Additionally the components for the hardware assembly were accounted for in this budget. These include the raw angle iron steel that was purchased for the generator and propane tank mount. The team had to purchase the fittings and hose to connect the propane tank to the generator as well as various nuts and bolts to secure the mounts onto the cart. Additionally, the mount fabrication was done by the team members, so sandpaper, drill bits, and cut off wheels were purchased to finalize these mounts.

In total all of the purchased components cost about \$2,790, which is \$10 under budget. A majority of the project budget, \$1,579, went to replacing broken components limiting the amount of money that could be used for the actual design and the reason for going over budget. Despite this Cummins was gracious enough to provide the team with the QG2800 generator free of charge as well as purchased the two RSP-1500 power supplies. A full bill of materials purchased for the project can be found in Appendix C.

### 7.3.2 Market Hybrid Golf Carts

On the market today, the Bad Boy buggies are the leading manufacturer of hybrid electric karts. The hybrid cart they manufacture is the AMBUSH ® iS which utilizes an electric or gas mode. The cart uses dual gas and has a four wheel drive option. It runs off a 16 hp direct current motor and uses four 12 volt batteries. This model starts at \$14,999 and has customizing options such as bucket seats, convertible rear seat kit, and folding windshield. [14]



**Figure 22. Bad Boy AMBUSH iS hybrid cart. [15]**

## 7.4 Communication

Communication between team members was continuous throughout the semester. Two group meetings were held every week. During these meetings group members updated the rest of the team on progress made. These meetings were also used to assign tasks to team members and to outline upcoming plans. In addition to these in-person meetings the team also communicated via text and email.

Bi-weekly meetings between the team and Dr. Gupta also occurred. In these meetings the team updated Dr. Gupta on progress made as well as got advice on various design or administrative issues encountered. In addition to these meetings the Team leader also meet with

Dr. Gupta and Dr. Ordonez for advice on elements of the circuit design. These latter meetings were not regular but were scheduled as necessary.

Communication with the sponsor consisted primarily of email correspondence, but also included phone calls. The sponsor's primary contact was Jakob, the team leader. It was initially intended to send progress updates every two weeks, however in reality updates were an average of one month apart. This was in part due to unexpected delays limiting the amount of progress made. Additionally it was hoped to update the sponsor with solutions to problems encountered rather than just the problems, this further extended the time between updates.

## 8 Conclusion

Cummins would like to develop a battery-engine package for semi-trucks that can activate the engine so it can charge the vehicle's battery when it is low. Cummins provided the design team with an electric golf cart and generator to model the semi-truck. The design team used the morphological method to determine solutions to the various design challenges. The design developed integrates a mechatronic system that activates the generator to charge the cart's batteries and power the cart's motor. Additionally the system incorporates heating pads so that the batteries will be maintained at their optimal operating temperature. The incorporation of all of these systems into the golf cart was done in a manner so as not to reduce the seating capacity and so that the cart can still operate when the batteries are charging. In order to ensure the design was reliable high factors of safety were used during component selection, and both FMEA and FEA analyses were performed. The total cost of the project is \$2,800, which is the total budget of the project. The team is proud of the design developed, but also realize that there is still room for improvement.

One of the initial goals of this project was for the generator to automatically activate when the measured battery charge is low. Due to complications with measuring the charge of the batteries it was ultimately decided to require user input to start the charging. Possible improvements for this design include developing a Coulomb counting system to calculate the batteries state of charge. Other improvements that could be made are making the system more user friendly. Since the developed design was more a proof- of-concept than an actual product

for market the functionality was given precedence over ease of use. Additional safe guards and weatherproofing could also be incorporated into the system to make it even more resistant to failure. Lastly as mentioned in section 4.4.1.3 the diodes connected to the batteries show signs of use so they should be replaced with higher rated diodes such as an APT30SCD120B diode.

## References

- [1] “Battery University”, Isidor Buchannan. April 06, 2016.  
[http://batteryuniversity.com/learn/article/charging\\_at\\_high\\_and\\_low\\_temperatures](http://batteryuniversity.com/learn/article/charging_at_high_and_low_temperatures)
- [2] Preece, Jeph. "Portable Power: Gas Generator vs. Propane Generator." *Top Ten Reviews*. Purch, 15 Aug. 2014. Web. 06 Apr. 2016.
- [3] Dieter, George E., and Linda C . Schmidt. "6.6 Morphological Methods." *Engineering Design*. New York: McGraw-Hill, 2013. 217. Print.
- [4] *Ironton Utility Trailer Kit*. Digital image. *Norther Tool + Equipment*. Norther Tool + Equipment, n.d. Web. 28 Oct. 2015.
- [5] "Cummins Generators." *Cummins Power Generation*. Cummins, n.d. Web. 29 Oct. 2015.
- [6] Tomberlin. E-MERGE 48SS. Augusta: Tomberlin, n.d. Print.
- [7] “RV Generator Set Quiet Gasolinetm Series RV QG 2800. 1st ed. Cummins, 2013. Web pdf.
- [8] U.s.auto. "OEM Prestolite, Ametek, Continuous,200 Amp, SBD 4201G, 15-386." *EBay*. N.p., n.d. Web. 06 Dec. 2015.
- [9] Product Manual For Quiq 912-48Xx. 1st ed. Burnaby: Delta-Q Technologies. Web pdf.
- [10] “Zerostart 2800071 - Battery Heater | O'reilly Auto Parts”. Oreillyauto.com. N.p., 2016. Web. 30 Mar. 2016.
- [11] "Lead-Acid Batteries- Hazards and Responsible Use." *Cal Recycle*. The State of California, n.d. Web.
- [12] "About Lead-Based Paint." *US Department of Housing and Urban Development*. US Government, n.d. Web.

- [13] Gromicko, Nick. "Generator Hazards and Inspection." *InterNACHI*. International Association of Certified Home Inspectors Inc., n.d. Web. 06 Dec. 2015.
- [14] *Bad Boy AMBUSH IS Hybrid Cart*. Digital image. *VIPgolfcarts*. VIP, n.d. Web. 2 Apr. 2016.
- [15] "Ambush IS." *Ambush IS*. Textron Specialized Vehicles, n.d. Web. 07 Apr. 2016.

## Appendix A

```

#include <Wire.h>
#include <LiquidCrystal_I2C.h>
LiquidCrystal_I2C lcd(0x20,16,2);

const int HP_pin = 13;    //pin for heating pad relay
const int CH_pin = 12;    //pin for charger relay
const int GEN1_pin = 11;  //pin for generator on relay
const int GEN2_pin = 10;  //pin for generator off relay
const int PS1_pin = 9;    //pin for power source relay 1
const int PS2_pin = 7;    //pin for power source relay 2

const int V_pin = A0;     //voltage pin
const int T_pin = A1;     //temperature pin
const int I_pin = A2;     //current pin

volatile int GENSET = 0;   //generator state 0:off 1:on
int HP = 0;                //heating pad state 0:off 1:on
int CH = 0;                //charger state 0:off 1:on

volatile int useron = 0;

int state = 1;            //state of system

const float T_low = 0;
const float T_fine = 20;
const float T_high = 50;

const float V100 = 52.0;  //V_m = 4.33;
const float V_charge = 50.0; //V_m = 4.08;

//current below which charger is done charging
const float I_stop = 0.5;

int N = 30;                //input sample size

/*****/
void setup()
{
  Serial.begin(9600);

  //initialize lcd
  lcd.init();
  lcd.backlight();

  //Set all digital pins as outputs set to low
  for (int j = 0; j < 14; j++)
  {
    if ((j ==2)|| (j == 3))

```



```
{
  pinMode(j, INPUT);
}
else
{
  pinMode(j, OUTPUT);
  digitalWrite(j, LOW);
}
delay(5);
}

//declare pin inputs
pinMode(V_pin, INPUT);
pinMode(T_pin, INPUT);
pinMode(I_pin, INPUT);

attachInterrupt(0, userstartup, FALLING);
//attachInterrupt(1, usershutdown, FALLING);

delay(2000);
}

void loop()
{
  int V_m_dig = 0;    //measured digital battery voltage
  int V_m_sum = 0;   //sum digital battery voltage

  int T_batt_dig = 0; //measured digital temperature
  int T_batt_sum = 0; //sum digital temperature

  int I_ch_dig = 0;  //measured digital current
  int I_ch_sum = 0;  //sum digital current

  //initialize sensor input variables
  float T_batt = 0.0;
  float V_batt = 0.0;
  float I_ch = 0.0;

  const float R1 = 1200000.0;
  const float R2 = 92300;

  for (int i = 0; i < N; i++)
  {
    //sensor inputs into A/D pins
    V_m_dig = analogRead(V_pin);
    delay(5);
    T_batt_dig = analogRead(T_pin);
    delay(5);
    I_ch_dig = analogRead(I_pin);
    delay(5);

    //calculate sum of inputs
    V_m_sum += V_m_dig;
  }
}
```

```

    T_batt_sum += T_batt_dig;
    I_ch_sum += I_ch_dig;
}

//calculate averaged digital values
V_m_dig = V_m_sum/N;
T_batt_dig = T_batt_sum/N;
I_ch_dig = I_ch_sum/N - 504;

V_batt = V_m_dig*(5.0/1023.0)*((R1+R2)/R2); //raw measured voltage (V)
T_batt = (100.0*(T_batt_dig*(5.0/1023.0)) - 50.0)/15.0; //remove 15
term when sensor is replaced
I_ch = I_ch_dig*(5000.0/1023.0)/40.0;

if (I_ch<0)
{
    I_ch = 5;
}

lcd.setCursor(0,0);
lcd.print("V: ");
lcd.print(V_batt);
lcd.setCursor(9,0);
lcd.print("T: ");
lcd.print(T_batt);
lcd.setCursor(0,1);
lcd.print("I: ");
lcd.print(I_ch);

//*****
switch (state)
{
    case 1:
        lcd.setCursor(9,1);
        lcd.print("State 1");
        delay(100);

        //if generator on change power source and turn off
        if (GENSET == 1)
        {
            if (HP == 1)
            {
                HPcontrol(0);
            }
            else
            {
                CHcontrol(0);
            }
            delay(1000); //delay to allow steady state formation
            powerBATT(); //switch to battery power
            delay(1000); //delay to allow steady state formation
            genstop(); //turn off generator

```

```

    }

    /*****/
    //change states based on sensor inputs
    if (T_batt < T_low)
    {
        state = 2;
    }
    else if ((T_batt > T_low)&&(useron == 1)) //&&(V_batt < V_charge)
    {
        state = 3;
    }

    break;
/*****/
case 2:
    lcd.setCursor(9,1);
    lcd.print("State 2");
    delay(100);

    //if generator off turn on
    if (GENSET == 0)
    {
        genstart();
        delay(5000);           //delay until generator fully operational
        powerGEN();           //switch to generator power
        delay(5000);           //delay until returned to steady state
        HPcontrol(1);         //turn heating pad on
    }
    else
    {
        if (CH == 1)
        {
            CHcontrol(0);     //cut power to charger
            delay(5000);       //delay until returned to steady state
        }

        HPcontrol(1);         //power heating pad
    }
/*****/

    //change states based on sensor inputs
    if ((T_batt > T_low)&&(V_batt < V_charge))
    {
        state = 3;
    }
    else if (T_batt > T_fine)
    {
        state = 1;
    }

    break;
/*****/

```

```

case 3:
  lcd.setCursor(9,1);
  lcd.print("State 3");
  delay(100);

  //if generator off turn on
  if (GENSET == 0)
  {
    genstart();
    delay(5000);      //delay until generator fully operational
    powerGEN();      //switch to generator power
    delay(5000);      //delay until returned to steady state
    CHcontrol(1);     //turn charger on
    delay(10000);
  }

  //If generator and heating pad on turn off heating pad and turn on
  charger
  if ((CH == 0)&&(HP == 1))
  {
    HPcontrol(0);     //cut power to heating pad
    delay(5000);      //delay until returned to steady state
    CHcontrol(1);     //power charger
    delay(10000);
  }

  /*****/

  //change states based on sensor inputs
  if ((I_ch < I_stop)&&(T_batt > T_low)&&(V_batt >= V100))
  {
    state = 1;
  }

  if (T_batt < T_low)
  {
    state = 2;
  }

  if (T_batt > T_high)
  {
    state = 4;
  }

  break;
/*****/
case 4:
  lcd.setCursor(9,1);
  lcd.print("State 4");
  delay(100);

  if (CH == 1)
  {

```

```

    CHcontrol(0);    //stop charging batteries
  }
  /*****/

  if (T_batt <= T_fine)
  {
    state = 3;
  }

  break;
}

}

//generator start up function
void genstart()
{
  delay(1000);
  digitalWrite(GEN1_pin,HIGH);
  delay(5000);
  digitalWrite(GEN1_pin,LOW);
  GENSET = 1;
}

//generator shut down function
void genstop()
{
  digitalWrite(GEN2_pin,HIGH);
  delay(2000);
  digitalWrite(GEN2_pin,LOW);
  GENSET = 0;
}

//Generator power source relay control function
void powerGEN()
{
  digitalWrite(PS1_pin,HIGH);
  digitalWrite(PS2_pin,HIGH);
}

//Battery power source relay control function
void powerBATT()
{
  digitalWrite(PS1_pin,LOW);
  digitalWrite(PS2_pin,LOW);
}

//Heating pad control function

void HPcontrol(int value)
{
  //cut power to heating pad
  if (value == 0)

```

```
{
  digitalWrite(HP_pin,LOW);
  HP = 0;
}
//power heating pads
else if (value == 1)
{
  digitalWrite(HP_pin,HIGH);
  HP = 1;
}
delay(5000);
}

void CHcontrol(int value)
{
  //cut power to charger
  if (value == 0)
  {
    digitalWrite(CH_pin,LOW);
    CH = 0;
  }
  //power charger
  else if (value == 1)
  {
    digitalWrite(CH_pin,HIGH);
    CH = 1;
  }
}

void userstartup()
{
  if (state != 1)
  {
  }
  else
  {
    useron = 1;
  }
}
```

# Appendix B

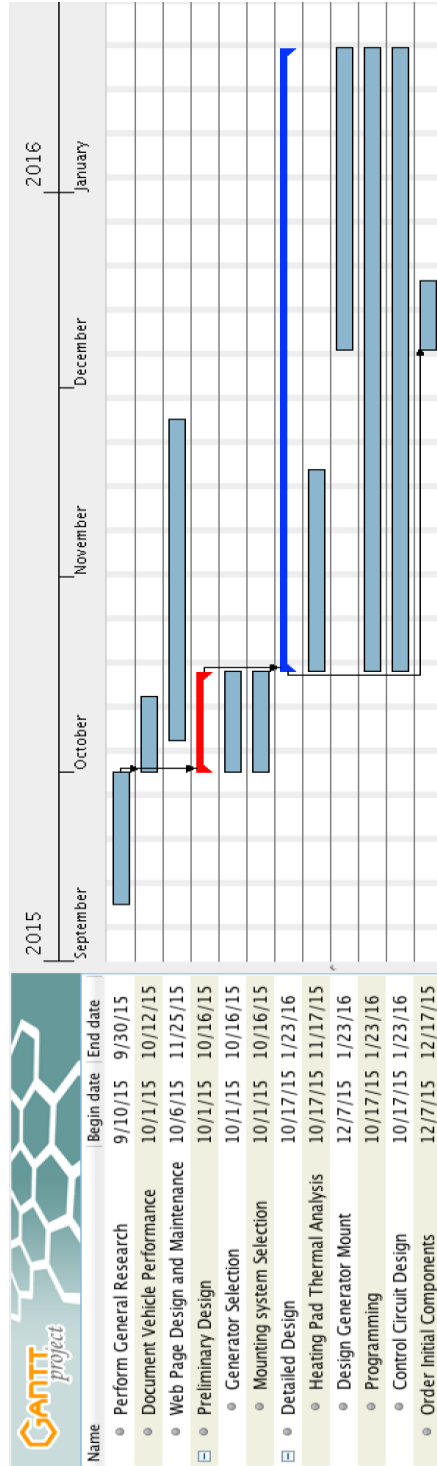

**Figure 23. Fall Semester Gantt Chart**

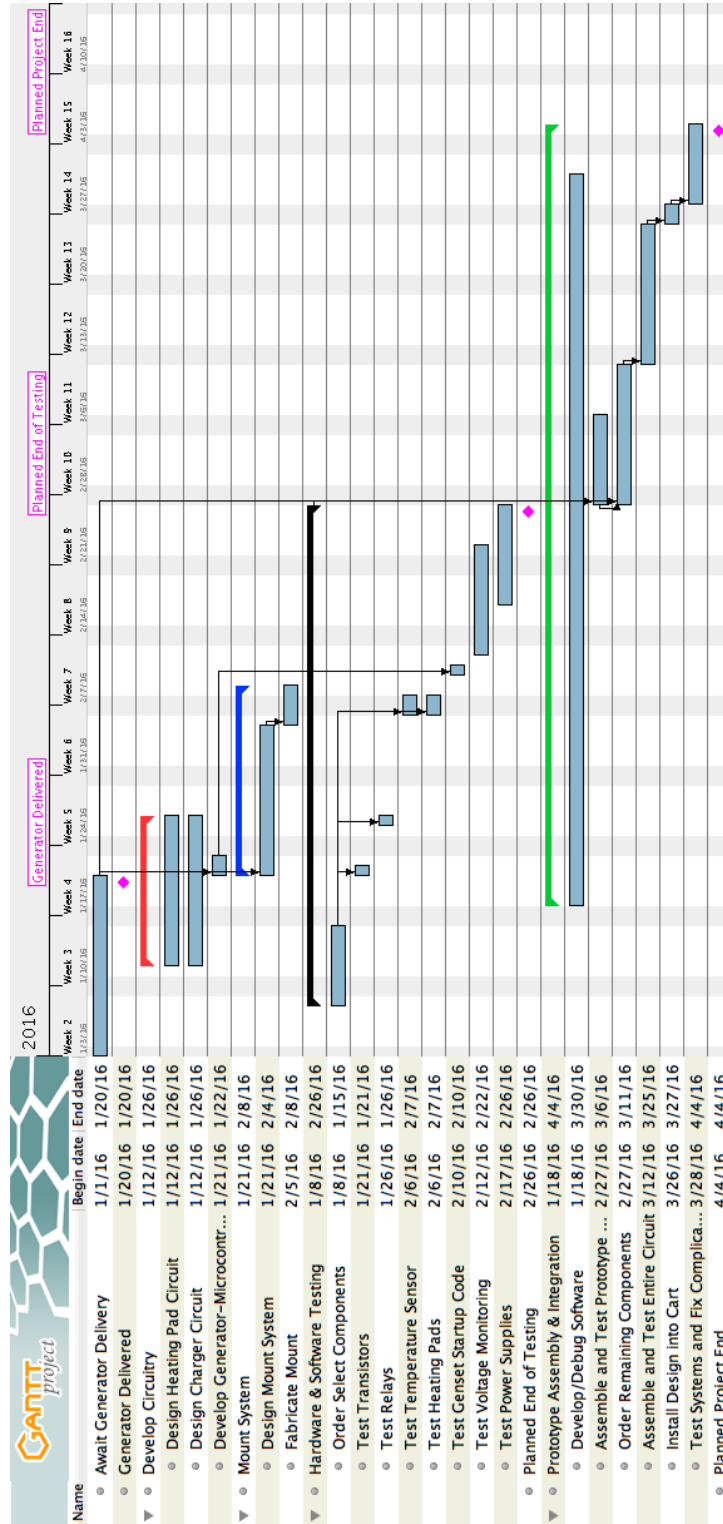

Figure 24. Spring Semester Gantt Chart.



## Appendix C

**Table 6. ME Purchases**

List of Parts Ordered	Unit Price	Quantity	Total
Ruggeduino Microcontroller	49.95	1	49.95
Arduino Uno Microcontroller	24.95	1	24.95
DFRobot 50A Current Sensor	14.55	1	14.55
I2C LCD1602 display	9.9	1	9.9
R55-11D20-12F DPDT Relay	6.55	2	13.1
SBD-4201G Ametek Relay	64.99	2	129.98
24-28AWG Crimp Female Connectors	0.05	15	0.75
2.54mm 6POS Screw Terminals	1.47	4	5.88
Terminal Block 75A 600V	8.74	3	36.22
QuiQ 912-48xx Charger	396	1	396
US 8VGC XC2 Lead Acid Battery	169	4	676
Odyssey PC1200MJT 12V Battery	209.95	1	209.95
Zerostart 160W Heating Pads	62.99	3	188.97
1/8"x 2"x2" Angle Bar		2	24.05
1/8"x 1-1/4" x 1-1/4" Angle Bar		1	9.56
Labor			18.75
Propane Tank / fitting		1	55.45
LP Hose	26.87	1	26.87
drill bit and bolts			22
Dry Ice (6lbs)	1.5		9
Thermometer	9.99	1	9.99
Sand Paper	2	1	2
cut off wheels	8	1	8
black zip ties	2	1	2
Motor Oil	4.29	1	4.29
<b>Sub total</b>			<b>1948.16</b>
<b>Budget Left</b>			<b>51.84</b>

**Table 7. EE Purchases**

List of Parts Ordered	Unit Price	Quantity	Total
US 8VGC XC2 Lead Acid Battery	169	3	507
3/8" Hex Bolt	0.11	8	0.88
3/8" Hex Nut	0.06	10	0.6
3/8" Lock Washer	0.15	10	1.5
5/16 Stainless Steel Nuts PKG.			3.26
small relay screws	0.48	2	0.96
M4 Hex Bolt	0.65	2	1.3
M4 Hex Nut	0.5	3	1.5
M4 Lock Washer	0.56	2	1.12
M3 lock washer	0.15	3	0.45
Relay lock washer	1.18	3	3.54
Wire Nut	2.15	1	2.15
Brass Hinge w/ Screws (2 pack)	2.47	1	2.47
12V Voltage Regulator 1.5A	7.95	2	15.9
12V Voltage Regulator 1.0A	4.25	2	8.5
TIP120-NPN Transistor	2.66	5	13.3
JM1aN-ZTM-DC12V-F SPST Relay	5.1	2	10.2
RHRG75120 75A 1.2kV Diode	5	6	30
200mA Fuse	0.32	15	4.8
1A Fuse	0.32	4	1.28
6A Fuse	0.71	2	1.42
300 V Fuse Block	3.86	3	11.58
Toggle switch	5.27	1	5.27
Protoboard Solder Board	5.95	2	11.9
Hook up wire 600V 16AWG	8.95	1	8.95
heat shrink	1.97	1	1.97
0.25" Male Terminal Connector 15 pack	2.49	1	2.49
0.25" Female Terminal Connector	2.49	1	2.49
0.187" Female Terminal Connector	2.74	1	2.74
5/16" Ring Terminal Connector	2.49	1	2.49
2AWG Wire (18 ft.)	2.33	18	41.94
5/16" 2AWG Ring Connector	1	42	42
3-D Printed Parts			30

Team 2

Electric Vehicle Optimization

Power cable 6 bulk	4.95	1	4.95
Battery Cables			30.08
Drill bit and star socket			13.96
Cut-off Wheel and Brass fittings			19.66
<b>Total</b>			<b>844.6</b>
<b>Budget Left</b>			<b>-44.6</b>